

We Make it Easy to Sort and Transfer



Ergo Roll® Multidirectional Conveyor Rollers

Description

A flexible and versatile conveyor roller that allows you to move, transfer and turn material smoothly and easily in ANY direction. The unique Ergo Roll design uses four free turning barrel shaped rollers mounted in a 90° staggered pattern around the perimeter of a main core wheel, allowing a multidirectional roller function.

Application

With unlimited applications, the modular roll design fits all conveyor transfer areas.

Ergonomic Benefit

- Eliminate employee strain, fatigue and injury.
- Create a safer and more productive work environment.

Standard Features

- Offers unprecedented flexibility in moving packages or products in any direction.
- Modular design provides maximum build flexibility and customization for any formation and application.
- No maintenance and lubrication required - ever.
- Each individual roller element, as well as the main core, is made of corrosion resistant polyacetal plastic.
- Lightweight, plastic construction with stainless steel axles.
- Plastic, no-bearing rollers prevent damaging, scuffing or marring of transferred material.
- Suitable for wet environments including submersion applications.
- Open construction which does not accumulate dirt or debris and prevents lock-up problems.
- Wide roller contact surface distributes the load therefore reducing indentation.
- The multidirectional roller function is optimized in a paired duplex configuration, but the simplex roller is a practical alternative for lighter weight applications.

Configuration Examples



Application Examples



Technical Information

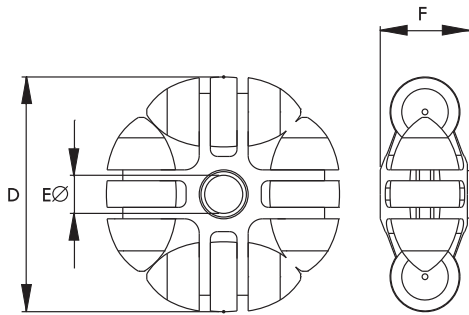

Simplex Roller

Model No.	Diameter (D)	Bore Size (E)	Typical Axle Size	Application	Width (F)	Unit Weight (oz.)	Load Capacity (lb.)
ER190S-14RG	1.9"	0.26"	1/4" Round	Gravity	0.65"	0.8	12.5
RF50S	2.0"	0.327"	5/16" Round	Gravity	0.768"	1.0	12.5
RF60S	2.36"	0.327"	5/16" Round	Gravity	0.985"	1.8	22.5
RF80S	3.15"	0.327"	5/16" Round	Gravity	1.182"	4.0	45.0

Duplex Roller

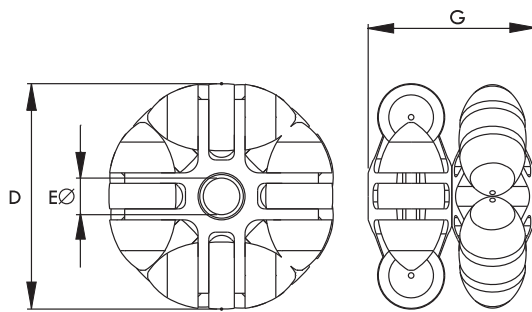

Model No.	Diameter (D)	Bore Size (E)	Typical Axle Size	Application	Width (G)	Unit Weight (oz.)	Load Capacity (lb.)
ER190D-14RG	1.9"	0.26"	1/4" Round	Gravity	1.3"	1.7	25.0
ER190D-516RG	1.9"	0.327"	5/16" Round	Gravity	1.3"	1.7	25.0
ER190D-516RD	1.9"	0.327"	5/16" Round	Driven	1.3"	1.7	25.0
ER190D-12RG	1.9"	0.544"	1/2" Round	Gravity	1.3"	1.7	25.0
ER190D-12RD	1.9"	0.544"	1/2" Round	Driven	1.3"	1.7	25.0
ER190D-716HG	1.9"	0.443"	7/16" Hex	Gravity	1.3"	1.7	25.0
ER190D-716HD	1.9"	0.443"	7/16" Hex	Driven	1.3"	1.7	25.0
RF50D	2.0"	0.327"	5/16" Round	Gravity	1.536"	2.0	25.0
RF60D	2.36"	0.327"	5/16" Round	Gravity	2.0"	3.6	45.0
RF80D	3.15"	0.327"	5/16" Round	Gravity	2.364"	8.0	90.0

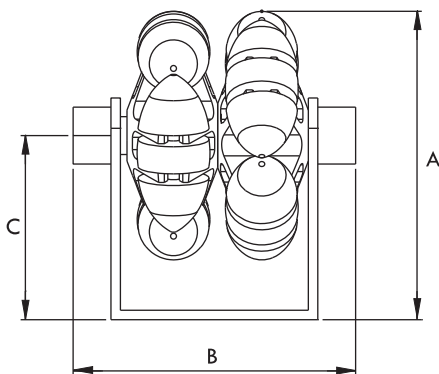

Roller in U-Profile

Model No.	Top Height (A)	Overall Width (B)	Center Height (C)
ER190	2.5"	2.2"	1.55"
RF50	2.5"	2.2"	1.52"
RF60	3.0"	2.7"	1.81"
RF80	3.75"	3.1"	2.17"

Roller in U-Profile Configurations

Length	Content	Model No.			
	1 Duplex Roller	50D01	60D01	80D01	
2'	6 Simplex Rollers	50S06	60S06	80S06	
2'	6 Duplex Rollers	50D06	60D06	80D06	ER190D06
2'	11 Simplex Rollers	50S11	60S11	80S11	
2'	11 Duplex Rollers	50D11	60D11	80D11	ER190D11
3'	9 Simplex Rollers	50S09	60S09	80S09	
3'	9 Duplex Rollers	50D09	60D09	80D09	ER190D09
3'	17 Duplex Rollers	50D17	60D17	80D17	ER190D17
5'	15 Simplex Rollers	50S15	60S15	80S15	
5'	15 Duplex Rollers	50D15	60D15	80D15	ER190D15
10'	30 Simplex Rollers	50S30	60S30	80S30	
10'	30 Duplex Rollers	50D30	60D30	80D30	ER190D30