

# We Make it Easy to Position



## Ergo Master<sup>®</sup> Manual Work Positioner

### Description

This versatile and safe work positioner enables you to move work to any suitable work position with easy up and down height adjustment, 360° rotation and tilt.

### Application

Ergo Master is ideal for secure positioning of any object for any project, no matter what size or shape. This manual work positioner offers unlimited applications in any industry and is advantageous in any warehouse, shop floor or work area.

### Ergonomic Benefit

- Eliminate employee strain, fatigue and injury.
- Create a safer and more productive work environment.

### Standard Features

- Designed and built in the USA for the most robust and heavy-duty applications.
- Offers full flexibility to move work to any work positions.
- Adaptable to any work fixtures.
- Solid aluminum construction with stainless steel ball.
- Available in bench (2 axis) or floor pillar mount (3 axis) configurations.
- Four standard load classes: 50 lbs., 150 lbs., 300 lbs., 400 lbs. (2-axis only).
- Provides a positive, safe and secure position lock instantaneously in any desired work position.
- Operator adjustable friction resistance assures a smooth and balanced transition between positions.
- One foot pedal controls the height position adjustment while the other foot pedal provides release for easy tilt and rotation.

### Options

- Slot in top block for 90° tilt.
- Protective dust and weld covers.
- Turn-table with 8 slots.
- Welding ground lug.
- Base casters.



Floor Mount  
w/optional 90° tilt

### Other Ergo Masters



Vertical Turn-table



Bench Mount

### Application Examples



## Technical Information

### 2-Axis (Tilt & Rotation) Bench Mount ERGO MASTER

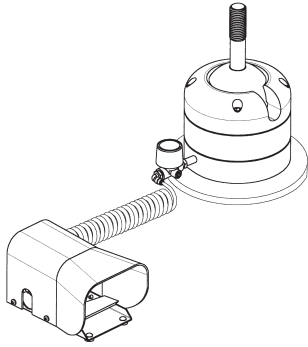

Model No.	Max. Dynamic Capacity (lbs.)	Cylinder Diameter (in.)	Cylinder Height (in.)	Overall Height w/Shaft (in.)	Shaft Thread Size	MOUNTING* Hole Pattern
EM50-F**	50	3 7/8	3 1/2	5 3/4	1/2" - 13	(4) - 9/32" dia. holes on a 4.50" dia. Bolt Circle
EM50-V**	50	3 7/8	3 1/2	8 1/4	1/2" - 13	(4) - 9/32" dia. holes on a 4.50" dia. Bolt Circle
EM150	150	6 7/16	6 1/8	11 1/4	1" - 8	(4) - 9/32" dia. holes on a 8.75" dia. Bolt Circle
EM300	300	7 7/8	6 7/8	12 7/8	1" - 8	(4) - 9/32" dia. holes on a 8.75" dia. Bolt Circle

\*For fastening, use bolts with minimum hardness grade of at least 8.8. Screw in at least 1" deep.  
 \*\* F indicates Fixture plate mounted on top (mounting hole pattern (4) - 9/32" dia. holes on a 2.375" dia. Bolt Circle).  
 \*\* V indicates Vice mounted on top.

### 3-Axis (Up/Down, Tilt & Rotation) Floor Mount ERGO MASTER

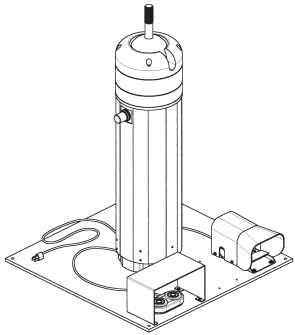

Model No.	Max. Dynamic Capacity (lbs.)	Retracted Height (in.)	Maximum Height (in.)	Stroke (in.)	Pillar Sections	Lift Speed (in./sec.)	Pillar Voltage (V)	Pillar Amperage (A)	Pillar Duty Cycle (at 68°F)
EM153	150	30 3/4	42 3/4	12	2	1.2	110/60Hz	5.0	Intermittent Service 20% Duty Cycle
EM154	150	34 3/4	50 3/4	16	2	1.2	110/60Hz	5.0	
EM303	300	32 3/8	44 3/8	12	2	1.2	110/60Hz	5.0	
EM304	300	36 3/8	52 3/8	16	2	1.2	110/60Hz	5.0	

For fastening to floor, use bolts with minimum hardness grade of at least 8.8. Screw in at least 1" deep.

### 1-Axis (Rotation) Bench Mount ERGO MASTER

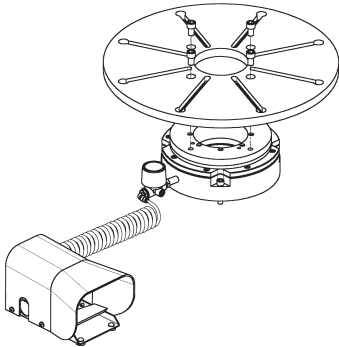

Model No.	Max. Dynamic Capacity (lbs.)	Height (in.)	Turntable Diameter (in.)	Turntable Thickness (in.)	Turntable Slot Size	Bolt Head Opening (in.)	MOUNTING* Hole Pattern
EM400	400	3 3/4	15 5/8	5/8	8 - 0.39" wide 45° apart	0.68	(4) - 13/32" dia. holes on a 7.75" Bolt Circle

\*For fastening, use bolts with minimum hardness grade of at least 8.8. Screw in at least 1" deep.

### 2-Axis (Up/Down & Rotation) Floor Mount ERGO MASTER

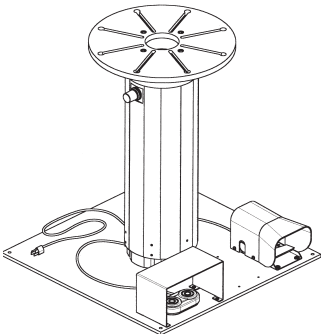

Model No.	Max. Dynamic Capacity (lbs.)	Retracted Height (in.)	Maximum Height (in.)	Stroke (in.)	Pillar Sections	Lift Speed (in./sec.)	Pillar Voltage (V)	Pillar Amperage (A)	Pillar Duty Cycle (at 68°F)
EM403	400	23	35	12	2	1.2	110/60Hz	5.0	Intermittent Service 20% Duty Cycle
EM404	400	27	43	16	2	1.2	110/60Hz	5.0	

For fastening to floor, use bolts with minimum hardness grade of at least 8.8. Screw in at least 1" deep.

NOTE: All models operate from standard shop air at minimum 80 psi.

#### Dynamic Load Capacity (% of Max. Capacity)

